

# LCD to HDMI converter

Without HDCP

U11 TDA19988BHN/C1

Inputs can withstand 3.3V, but not 5V

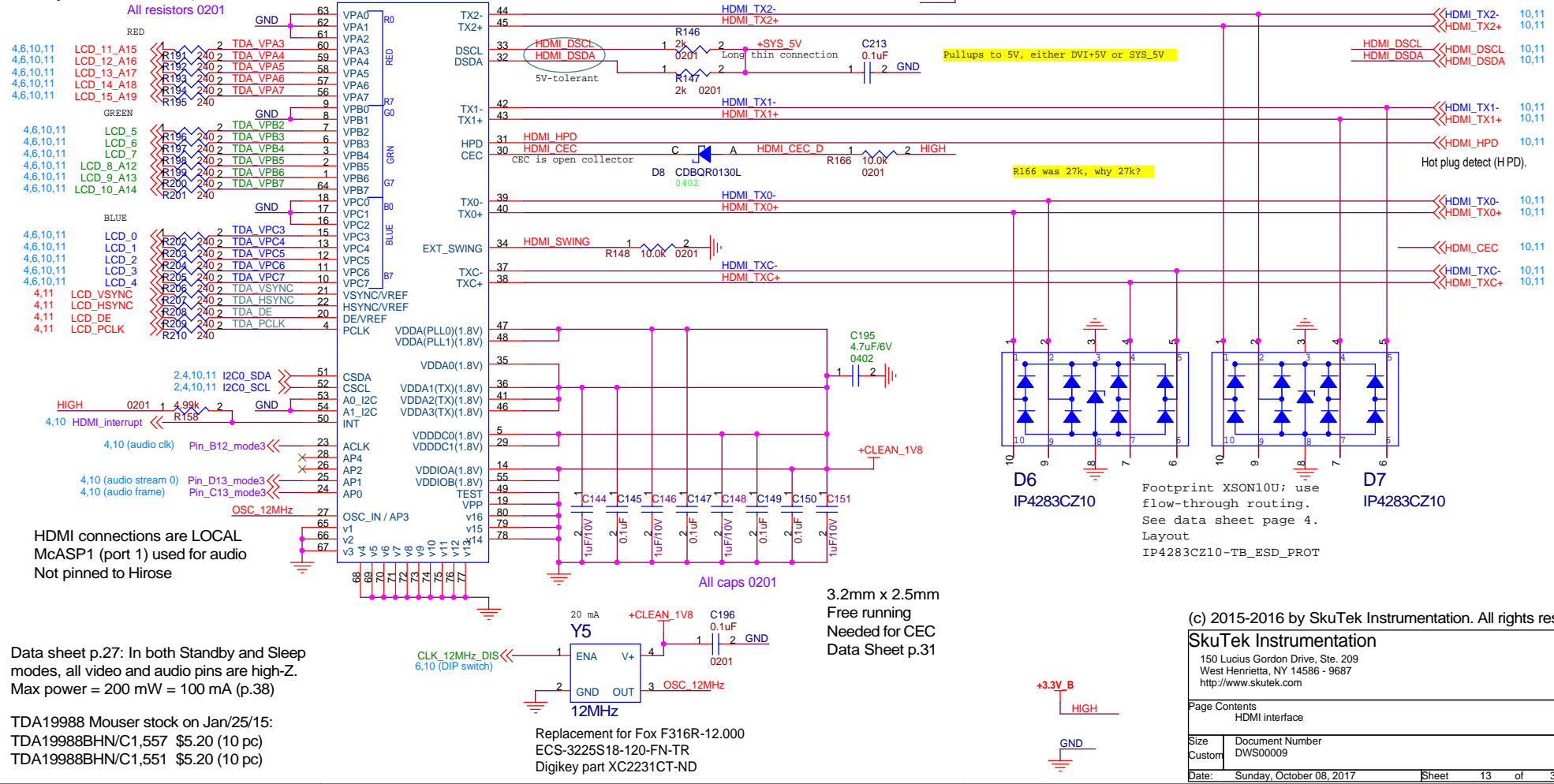

(c) 2015-2016 by SkuTek Instrumentation. All rights reserved.

**SkuTek Instrumentation**  
 150 Lucius Gordon Drive, Ste. 209  
 West Henrietta, NY 14586 - 9687  
 http://www.skutek.com

Page Contents		
HDMI interface		
Size	Document Number	Rev
Custom	DWS00009	1
Date:	Sunday, October 08, 2017	Sheet 13 of 32